

SIEMENS

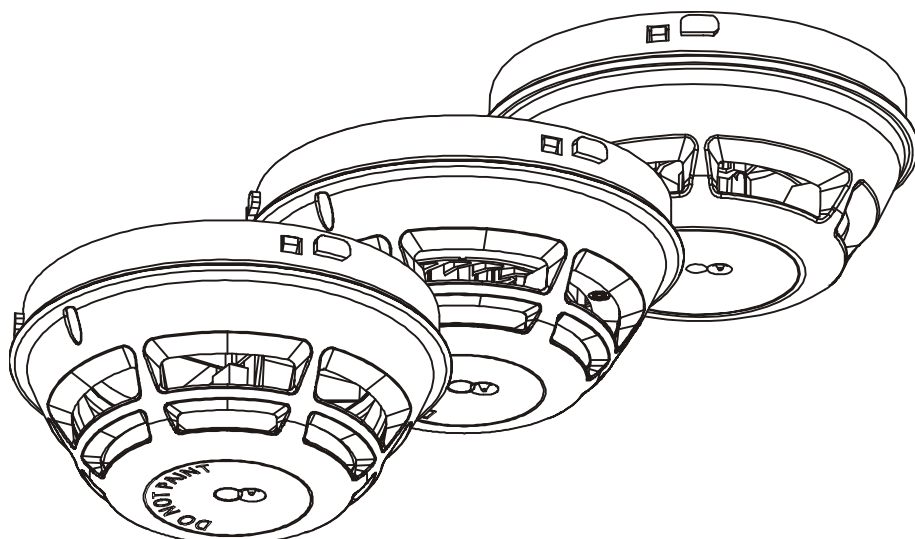

OH720, OP720, HI720, HI722

Automatic fire detectors

Technical Manual

Legal notice

Technical specifications and availability subject to change without notice.

Transmittal, reproduction, dissemination and/or editing of this document as well as utilization of its contents and communication thereof to others without express authorization are prohibited. Offenders will be held liable for payment of damages. All rights created by patent grant or registration of a utility model or design patent are reserved.

Issued by:
Siemens Switzerland Ltd.
Building Technologies Division
International Headquarters
Gubelstrasse 22
CH-6301 Zug
Tel. +41 41 724-2424
www.siemens.com/buildingtechnologies

Edition: 2016-11-15
Document ID: A6V10212047_n_en_--

© Siemens Switzerland Ltd, 2008

Table of contents

1	About this document	5
1.1	Applicable documents.....	7
1.2	Download center.....	7
1.3	Technical terms.....	7
1.4	History of changes.....	8
2	Safety	10
2.1	Intended use.....	10
2.2	Safety instructions.....	10
2.3	Safety regulations for the method of operation.....	12
2.4	Standards and directives complied with.....	14
2.5	Release Notes.....	14
3	Structure and function	15
3.1	Overview.....	15
3.1.1	Details for ordering.....	15
3.1.2	Product version ES.....	16
3.2	Point detector.....	17
3.2.1	Multi-sensor smoke detector.....	17
3.2.2	Smoke detector.....	18
3.2.3	Heat detector.....	19
3.3	Function.....	20
3.3.1	Parameter sets.....	20
3.3.2	Danger levels.....	20
3.3.3	Diagnosis levels.....	20
3.3.4	Line separator.....	21
3.3.5	Internal alarm indicator in the case of ES <10.....	21
3.3.6	Extended flashing behavior of alarm indicators in the case of ES ≥10	22
3.3.7	Connection for external alarm indicators.....	23
3.3.8	Test mode.....	23
3.3.9	Behavior in degraded mode.....	24
3.3.10	Line tester.....	24
3.4	Mechanical setup.....	25
3.5	Accessories.....	26
3.5.1	Detector base with loop contact DB721.....	26
3.5.2	Detector base DB722.....	26
3.5.3	Detector base DB720.....	27
3.5.4	Sounder base DBS720.....	27
3.5.5	Designation plate FDBZ291.....	28
3.5.6	Detector base seal RS720.....	28
3.5.7	Base attachment BA720.....	28
3.5.8	Base attachment wet BA721.....	29
3.5.9	Designation plate DBZ1193A.....	29

3.5.10	Detector heating unit FDBH291.....	29
3.5.11	Protective cage DBZ1194	30
3.5.12	Detector locking device LP720.....	30
3.5.13	Micro terminal DBZ1190-AA.....	30
3.5.14	Connection terminal DBZ1190-AB.....	31
4	Planning	32
4.1	Compatibility.....	32
4.2	Multi-sensor smoke detector.....	33
4.2.1	Parameter sets	33
4.2.2	Specifications	33
4.3	Smoke detector	34
4.3.1	Parameter sets	34
4.3.2	Specifications	34
4.4	Heat detector.....	35
4.4.1	Parameter sets	35
4.4.2	Specifications	35
5	Mounting / Installation.....	36
5.1	Required space	36
5.2	Detector base DB72x.....	37
5.3	Sounder base DBS720	39
5.4	Detector base seal RS720	40
5.5	Base attachment BA720	41
5.6	Base attachment wet BA721	42
5.7	Detector locking device LP720.....	45
5.8	Designation plate FDBZ291	46
5.9	Cable entry.....	47
5.9.1	Auxiliary terminals DBZ1190-AA-AB.....	48
5.10	Detector lines	48
5.10.1	Connection diagram, addressed.....	48
5.11	Detector dust cap	50
5.12	Detector heating unit FDBH291	51
5.12.1	Installation of the detector heating unit	51
5.12.2	Connection of the detector heating unit	52
6	Commissioning.....	53
6.1	Commissioning on the C-NET.....	53
7	Maintenance / Repair	54
7.1	Performance check.....	54
7.2	Testing detectors.....	54
8	Specifications	55
8.1	Multi-sensor smoke detector technical data.....	55
8.2	Smoke detector technical data.....	57
8.3	Heat detector technical data	59
8.4	Dimensions	61
8.5	Environmental compatibility	61
Index		62

1 About this document

Goal and purpose

This document contains information on automatic fire detectors. Following the instructions consistently will ensure that the product can be used safely and without any problems.

Scope

The document is valid for the following automatic fire detectors:

- OH720
- OP720
- HI720
- HI722

Target groups

The information in this document is intended for the following target groups:

Target group	Activity	Qualification
Product Manager	<ul style="list-style-type: none"> • Is responsible for information passing between the manufacturer and regional company. • Coordinates the flow of information between the individual groups of people involved in a project. 	<ul style="list-style-type: none"> • Has obtained suitable specialist training for the function and for the products. • Has attended the training courses for Product Managers.
Project Manager	<ul style="list-style-type: none"> • Coordinates the deployment of all persons and resources involved in the project according to schedule. • Provides the information required to run the project. 	<ul style="list-style-type: none"> • Has obtained suitable specialist training for the function and for the products. • Has attended the training courses for Project Managers.
Project engineer	<ul style="list-style-type: none"> • Sets parameters for product depending on specific national and/or customer requirements. • Checks operability and approves the product for commissioning at the place of installation. • Is responsible for troubleshooting. 	<ul style="list-style-type: none"> • Has obtained suitable specialist training for the function and for the products. • Has attended the training courses for Product Engineer.
Installation personnel	<ul style="list-style-type: none"> • Assembles and installs the product components at the place of installation. • Carries out a performance check following installation. 	<ul style="list-style-type: none"> • Has received specialist training in the area of building installation technology or electrical installations.
Maintenance personnel	<ul style="list-style-type: none"> • Carries out all maintenance work. • Checks that the products are in perfect working order. • Searches for and corrects malfunctions. 	<ul style="list-style-type: none"> • Has obtained suitable specialist training for the function and for the products.

Source language and reference document

- The source/original language of this document is German (de).
- The reference version of this document is the international version in English. The international version is not localized.

Document identification

The document ID is structured as follows:

ID code	Examples
ID_ModificationIndex_Language_COUNTRY -- = multilingual or international	A6V10215123_a_de_DE A6V10215123_a_en_-- A6V10315123_a_--_--

Date format

The date format in the document corresponds to the recommendation of international standard ISO 8601 (format YYYY-MM-DD).

Conventions for text marking

Markups

Special markups are shown in this document as follows:

>	Requirement for a behavior instruction
1. 2.	Behavior instruction with at least two operation sequences
–	Version, option, or detailed information for a behavior instruction
⇒	Intermediate result of a behavior instruction
⇒	End result of a behavior instruction
•	Numbered lists and behavior instructions with an operation sequence
[→ X]	Reference to a page number
'Text'	Quotation, reproduced identically
<Key>	Identification of keys
>	Relation sign and for identification between steps in a sequence, e.g., 'Menu bar' > 'Help' > 'Help topics'
↑ Text	Identification of a glossary entry

Supplementary information and tips



The 'i' symbol identifies supplementary information and tips for an easier way of working.

1.1 Applicable documents

Document ID	Name
008115	Installation Detector heating FDBH291
008250	Technical Manual Line tester FDUL221
A6V10200373	Installation Detector base with loop contact DB721, DB722, detector base DB720, sounder base DBS720, detector base seal RS720, detector locking device LP720, base attachment BA720
A6V10201731	Installation Detector exchanger DX791, adapter for detector exchanger FDUD491
A6V10202198	Data sheet Automatic fire detectors OH720, OP720, HI720, HI722
A6V10203222	Data Sheet Testequipment and accessories FDUL221, DX791, RE6, RE7T, RE8ST, RE8STCO, FDUM29x, LE3, StabexHF
A6V10229261	List of compatibility (for 'Cerberus™ PRO' product line)
A6V10254740	Operating instructions Solo461 heat detector tester kit RE7T
A6V10387053	Installation RE8ST Testifire 1001-101 ST test kit, RE8STCO Testifire 2001-101 STCO test kit
A6V10406006	Installation Base attachment wet BA721, Detector designation plate DBZ1193A, Protective cage DBZ1194, EMC-protective cage FDBZ294
A6V10882301	List of compatibility (for 'FC360' product line)

Please also observe the documentation for your fire detection system.

1.2 Download center

You can download various types of documents, such as data sheets, installation instructions, and license texts via the following Internet address:

<http://siemens.com/bt/download>

- Enter the document ID in the 'Find by keyword' input box.



You will also find information about search variants and links to mobile applications (apps) for various systems on the home page.

1.3 Technical terms

Term	Explanation
AI	Alarm indicator
C-NET	Addressed detector line
EAI	External alarm indicator
ES	Product version
IAI	Internal alarm indicator

1.4 History of changes

The reference document's version applies to all languages into which the reference document is translated.



The first edition of a language version or a country variant may, for example, be version 'd' instead of 'a' if the reference document is already this version.

The table below shows this document's revision history:

Modification index	Edition date	Brief description
n	2016-11-15	<ul style="list-style-type: none"> 'Applicable documents', 'Test mode', and 'Testing detectors' chapters: RE8ST detector tester added 'Safety' chapter: 'Intended use' added Compatibility with fire detection system FC360 added Editorial adjustments
m	2015-05-04	Information about the extended flashing behavior inserted
l	2014-10-24	Flashing behavior updated Additions to the 'Internal alarm indicator' chapter
k	2014-09-12	Additions to the 'Technical data' chapters
j	2014-03-04	Change to date format in line with ISO 8601 specifications (yyyy-mm-dd format); various changes in the 'Specifications' chapter; editorial changes; base attachment wet BA721, designation plate DBZ1193A, protective cage DBZ1194, EMC-protective cage FDBZ294, and detector heating unit FDBH291 added, data sheet in 'Applicable documents' chapter added; 'Download center' chapter added; 'Internal alarm indicator' chapter revised
i	10.2011	Detector base DB722 and base attachment BA720 added, marine approval added, max. operating temperature changed to 55 °C, 'Product version' chapter added
h	03.2011	Connection diagram corrected
g	09.2010	FM approvals added
f	04.2010	New external alarm indicators added, minor editorial changes
e	09.2009	LPCB approvals added
d	08.2009	Detector base with loop contact DB721 added
c	04.2009	Cable cross section for detector base specified and minor editorial changes made VdS approval and CPD no. added
b	10.2008	Protection classes changed
a	09.2008	First edition

The table below shows the published language versions with the corresponding modification index:

Modification index	en_--	de_--	fr_--	it_--	es_--
n	X	X	X	X	X
m	X	X	X	X	X
l	X	X	X	X	X
k	–	X	–	–	–
j	X	X	X	X	X
i	X	X	X	X	X
h	X	X	X	X	X
g	X	X	X	X	X
f	X	X	X	X	X
e	X	X	–	–	–
d	X	X	X	X	X
c	X	X	X	X	X
b	X	X	X	X	X
a	X	X	X	X	X

X = published

– = no publication with this modification index

2 Safety

2.1 Intended use

The automatic fire detectors OH720, OP720, HI720, and HI722 may only be used on a C-NET detector line in a FS720 or FC360 fire detection system.

2.2 Safety instructions

The safety notices must be observed in order to protect people and property. The safety notices in this document contain the following elements:

- Symbol for danger
- Signal word
- Nature and origin of the danger
- Consequences if the danger occurs
- Measures or prohibitions for danger avoidance

Symbol for danger



This is the symbol for danger. It warns of **risks of injury**.
Follow all measures identified by this symbol to avoid injury or death.

Additional danger symbols

These symbols indicate general dangers, the type of danger or possible consequences, measures and prohibitions, examples of which are shown in the following table:



General danger



Explosive atmosphere



Voltage/electric shock



Laser light



Battery



Heat

Signal word

The signal word classifies the danger as defined in the following table:

Signal word	Danger level
DANGER	DANGER identifies a dangerous situation, which will result directly in death or serious injury if you do not avoid this situation.
WARNING	WARNING identifies a dangerous situation, which may result in death or serious injury if you do not avoid this situation.
CAUTION	CAUTION identifies a dangerous situation, which could result in slight to moderately serious injury if you do not avoid this situation.
<i>NOTICE</i>	<i>NOTICE</i> identifies possible damage to property that may result from non-observance.

How risk of injury is presented

Information about the risk of injury is shown as follows:

	<p>⚠ WARNING</p>
	<p>Nature and origin of the danger Consequences if the danger occurs</p> <ul style="list-style-type: none"> • Measures / prohibitions for danger avoidance

How possible damage to property is presented

Information about possible damage to property is shown as follows:



	<p><i>NOTICE</i></p>
	<p>Nature and origin of the danger Consequences if the danger occurs</p> <ul style="list-style-type: none"> • Measures / prohibitions for danger avoidance

2.3 Safety regulations for the method of operation

National standards, regulations and legislation

Siemens products are developed and produced in compliance with the relevant European and international safety standards. Should additional national or local safety standards or legislation concerning the planning, mounting, installation, operation or disposal of the product apply at the place of operation, then these must also be taken into account together with the safety regulations in the product documentation.

Electrical installations

	<p>⚠ WARNING</p>
	<p>Electrical voltage Electric shock</p> <ul style="list-style-type: none"> • Work on electrical installations may only be carried out by qualified electricians or by instructed persons working under the guidance and supervision of a qualified electrician, in accordance with the electrotechnical regulations.
<ul style="list-style-type: none"> • Wherever possible disconnect products from the power supply when carrying out commissioning, maintenance or repair work on them. • Lock volt-free areas to prevent them being switched back on again by mistake. • Label the connection terminals with external voltage using a 'DANGER External voltage' sign. • Route mains connections to products separately and fuse them with their own, clearly marked fuse. • Fit an easily accessible disconnecting device in accordance with IEC 60950-1 outside the installation. • Produce earthing as stated in local safety regulations. 	
	<p>⚠ CAUTION</p>
	<p>Noncompliance with the following safety regulations Risk of injury to persons and damage to property</p> <ul style="list-style-type: none"> • Compliance with the following regulations is required.
	<ul style="list-style-type: none"> • Specialist electrical engineering knowledge is required for installation. • Only an expert is permitted to carry out installation work. <p>Incorrect installation can take safety devices out of operation unbeknown to a layperson.</p>

Mounting, installation, commissioning and maintenance

- If you require tools such as a ladder, these must be safe and must be intended for the work in hand.
- When starting the fire control panel ensure that unstable conditions cannot arise.
- Ensure that all points listed in the 'Testing the product operability' section below are observed.
- You may only set controls to normal function when the product operability has been completely tested and the system has been handed over to the customer.

Testing the product operability

- Prevent the remote transmission from triggering erroneously.
- If testing building installations or activating devices from third-party companies, you must collaborate with the people appointed.
- The activation of fire control installations for test purposes must not cause injury to anyone or damage to the building installations. The following instructions must be observed:
 - Use the correct potential for activation; this is generally the potential of the building installation.
 - Only check controls up to the interface (relay with blocking option).
 - Make sure that only the controls to be tested are activated.
- Inform people before testing the alarm devices and allow for possible panic responses.
- Inform people about any noise or mist which may be produced.
- Before testing the remote transmission, inform the corresponding alarm and fault signal receiving stations.

Modifications to the system design and the products

Modifications to the system and to individual products may lead to faults, malfunctioning and safety risks. Written confirmation must be obtained from Siemens and the corresponding safety bodies for modifications or additions.

Modules and spare parts

- Components and spare parts must comply with the technical specifications defined by Siemens. Only use products specified or recommended by Siemens.
- Only use fuses with the specified fuse characteristics.
- Wrong battery types and improper battery changing lead to a risk of explosion. Only use the same battery type or an equivalent battery type recommended by Siemens.
- Batteries must be disposed of in an environmentally friendly manner. Observe national guidelines and regulations.

Disregard of the safety regulations

Before they are delivered, Siemens products are tested to ensure they function correctly when used properly. Siemens disclaims all liability for damage or injuries caused by the incorrect application of the instructions or the disregard of danger warnings contained in the documentation. This applies in particular to the following damage:

- Personal injuries or damage to property caused by improper use and incorrect application
- Personal injuries or damage to property caused by disregarding safety instructions in the documentation or on the product
- Personal injury or damage to property caused by poor maintenance or lack of maintenance

2.4 Standards and directives complied with

A list of the standards and directives complied with is available from your Siemens contact.

2.5 Release Notes

Limitations to the configuration or use of devices in a fire detection installation with a particular firmware version are possible.

	⚠ WARNING
	<p>Limited or non-existent fire detection</p> <p>Personal injury and damage to property in the event of a fire.</p> <ul style="list-style-type: none"> • Read the 'Release Notes' before you plan and/or configure a fire detection installation. • Read the 'Release Notes' before you carry out a firmware update to a fire detection installation.

	NOTICE
	<p>Incorrect planning and/or configuration</p> <p>Important standards and specifications are not satisfied. Fire detection installation is not accepted for commissioning. Additional expense resulting from necessary new planning and/or configuration.</p> <ul style="list-style-type: none"> • Read the 'Release Notes' before you plan and/or configure a fire detection installation. • Read the 'Release Notes' before you carry out a firmware update to a fire detection installation.

3 Structure and function

3.1 Overview

In this document the following point detectors are referred to collectively using the term 'Automatic fire detectors':

- Multi-sensor smoke detector OH720
- Smoke detector OP720
- Heat detector (static and differential) HI720
- Heat detector (static only) HI722

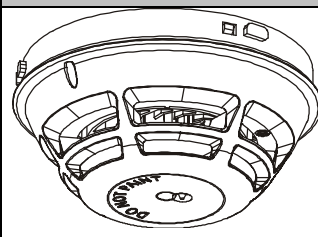
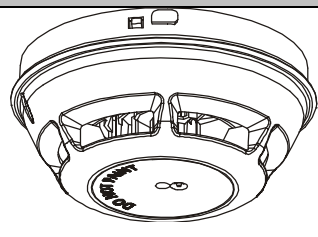
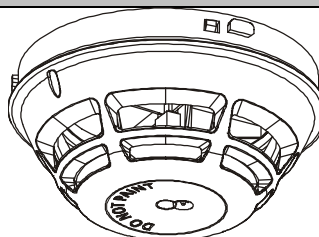
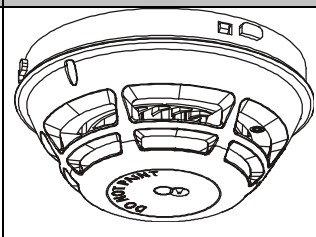
Multi-sensor smoke detector OH720	Smoke detector OP720	Heat detector (static and differential) HI720	Heat detector (static only) HI722
			
Can be used addressed on the C-NET	Can be used addressed on the C-NET	Can be used addressed on the C-NET	Can be used addressed on the C-NET
2 parameter sets		1 parameter set	
Detection behavior can be selected			Detection behavior cannot be selected

3.1.1 Details for ordering

Type	Order number	Designation
OH720	S54310-F2-A1	Multi-sensor smoke detector
OP720	S54310-F1-A1	Smoke detector
HI720	S54310-F4-A1	Heat detector (static and differential)
HI722	S54310-F3-A1	Heat detector (static only)

3.1.2 Product version ES

The product version ES provides the technical status of a device in terms of software and hardware. The product version is provided as a two-digit number.

You will find the details of your device's product version:

- On the packaging label
- On the product label or the type plate

Product version on the packaging label

Details of the product version can be found directly on the packaging label in the barcode:

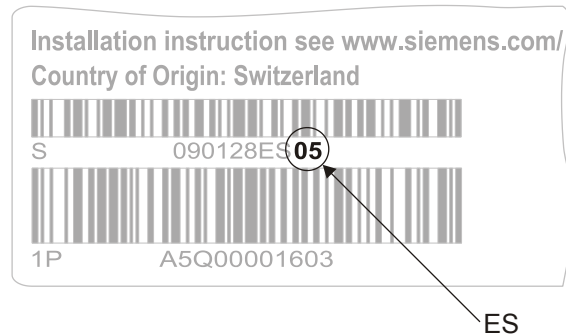

Figure 1: Example of a packaging label with details of the product version

Product version on the product label and the type plate

Details of the product version can be found after the device order number:

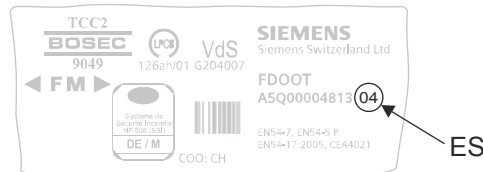

Figure 2: Example of a product label with details of the product version



Depending on the product and various approvals, the product labels may differ in terms of the information type and layout.

Look for your device's order number on the product label.

You will find the product version after the order number.

3.2 Point detector

3.2.1 Multi-sensor smoke detector

The multi-sensor smoke detector OH720 is a multiple criteria fire detector with one optical and one thermal sensor.

Structure and function

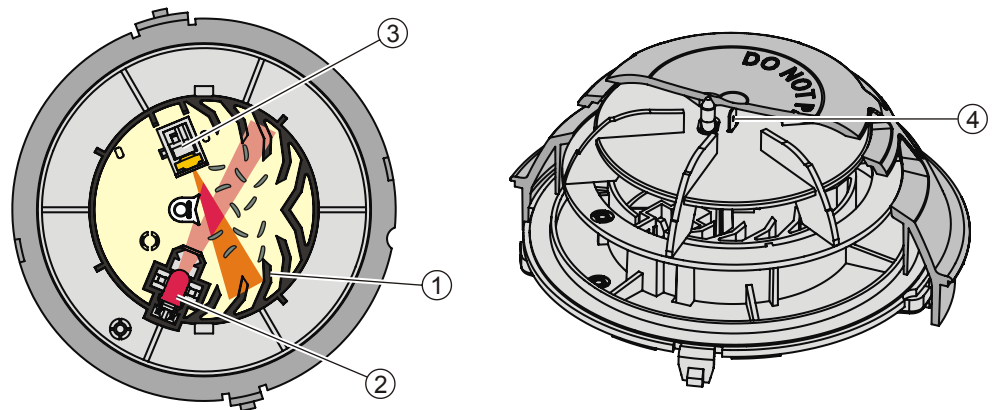

1 Labyrinth

2 Optical transmitter

3 Optical receiver

4 Heat sensor

The detector has a high-quality opto-electronic measuring chamber. The measuring chamber contains:

- One optical transmitter
- One optical receiver
- One thermal sensor

The transmitter lights up the smoke particles. The scattered light then hits the receiver (photodiode) and generates a measurable electric signal.

In addition, the heat sensor makes it possible to detect fires in cases where no smoke has been generated.

The combination of optical and thermal sensor signals optimizes detection reliability with the following benefits.

- Early detection of all types of fire, whether they generate light or dark smoke, or no smoke at all.
- The fire detector can be operated at a lower sensitivity level, thus achieving improved immunity against false alarms which may be caused by cold aerosols. In the event of an open fire, the smoke sensitivity level is raised by an increase in temperature which makes rapidly burning fires easier to detect.

The multi-sensor smoke detector OH720 has two parameter sets: 'Robust' and 'Sensitive'.

The multi-sensor smoke detector is addressed by the control panel when first switched on.

If a short-circuit occurs, the defective part on the detector line is located by the control panel and isolated between two detectors. In addition, a loop line installation ensures an optimum level of safety.

See also

📖 Multi-sensor smoke detector [→ 33]

3.2.2 Smoke detector

The wide-spectrum smoke detector OP720 is an optical smoke detector with an optical sensor.

Structure and function

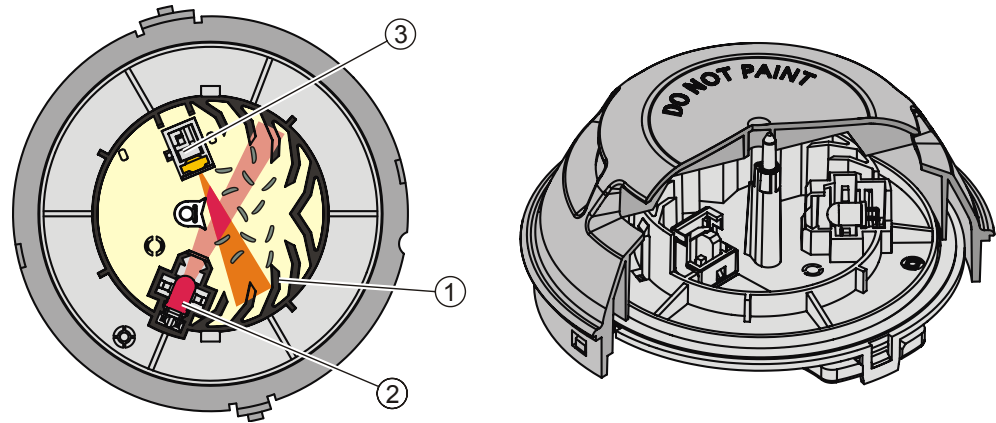

1 Labyrinth

3 Optical receiver

2 Optical transmitter

The wide-spectrum smoke detector has the same measuring chamber as the multi-sensor smoke detector.

The smoke detector OP720 addresses itself automatically when the control panel is first switched on, thus enabling individual identification in the event of an alarm.

If a short-circuit occurs, the defective part on the detector line is located by the control panel and isolated between two detectors. In addition, a loop line installation ensures an optimum level of safety.

The smoke detector OP720 has two parameter sets: 'Standard' and 'Sensitive'.

See also

☰ Smoke detector [→ 34]

3.2.3 Heat detector

The heat detectors HI720 and HI722 have a straightforward design featuring a thermal sensor.

The following table indicates the most important differences between the two heat detectors.

	HI720	HI722
Alarm activation by:	<ul style="list-style-type: none"> • Temperature increase • Reaching the maximum temperature 	<ul style="list-style-type: none"> • Reaching the maximum temperature
Number of parameter sets	2	1

Structure and function

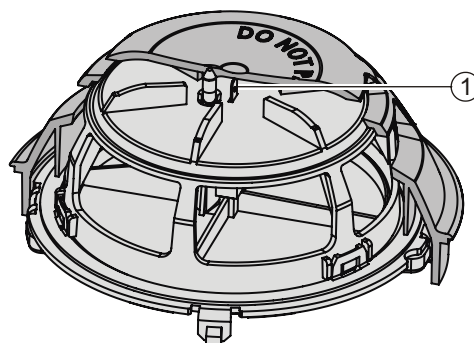

1 Heat sensor

The heat detector HI720 has two parameter sets: 'A2S' (static) and 'A2R' (differential).

The heat detector HI722 has one parameter set: 'A2S' (static).

The heat detectors HI720 and HI722 address themselves automatically when the control panel is first switched on, thus enabling individual identification in the event of an alarm.

If a short-circuit occurs, the defective part on the detector line is located by the control panel and isolated between two detectors. In addition, a loop line installation ensures an optimum level of safety.

See also

📄 Heat detector [→ 35]

3.3 Function

3.3.1 Parameter sets

The detection behavior of the detectors is influenced by the parameter sets, so that it can be specifically adjusted to the fire phenomena and environmental conditions to be expected in the environment to be monitored.

All parameter sets are programmed in the detectors. During commissioning, the optimum parameter set must be selected for the conditions at the place of installation. On a C-NET detector line, this is carried out at the control panel.

3.3.2 Danger levels

Measured values above a "response threshold" are not the only basis for reaching a danger level. The smoke density progression is also observed over a longer period of time and evaluated using algorithms.

Fire detectors can transmit the following danger levels to the control panel:

Danger level	Meaning	Comment
0	No danger	Normal condition
1	Check situation	A different parameter set should potentially be selected (inappropriate application)
2	Warning	Possible danger
3	Alarm	Fire

Each fire detector has danger levels 0...3.



The evaluation of the danger level and the decisions to be taken (e.g., activation of remote transmission) are configured in the relevant control panel.

3.3.3 Diagnosis levels

The point detector monitors most of its functions itself. In particular it monitors the correct functioning of the microcontroller, temperature sensors, light emitter and light receiver.

The following diagnosis levels are derived from the different control measurements:

- Normal
- Observe information
- Replacement recommended
- Replacement necessary
- Fault

When a fatal error occurs, which prevents the proper function of the detector, a fault message is signaled.

3.3.4 Line separator

All C-NET devices are equipped with a line separator.

The C-NET device is equipped with electronic switches which isolate the defective part in case of a short-circuit on the C-NET detector line. The rest of the detector line remains serviceable. On a loop line, all C-NET devices remain fully functional after a single short-circuit.

3.3.5 Internal alarm indicator in the case of ES <10

The point detectors have an internal alarm indicator. The internal alarm indicator shows the point detector's operating status:

Operating condition	Flashing mode of the IAI
Normal	IAI off
Alarm	IAI lights up every second
Test mode	IAI off
Alarm in test mode	IAI lights up every second



The flashing behavior of the point detectors in the case of ES ≥ 10 is described in the 'Extended flashing behavior of alarm indicators in the case of ES ≥ 10 [→ 22]' chapter.



Information about the product version of your device can be found in the 'Product version ES [→ 16]' chapter.



3.3.6 Extended flashing behavior of alarm indicators in the case of $ES \geq 10$

Internal alarm indicators

The table below describes the flashing behavior of internal alarm indicators in the case of an $ES \geq 10$:

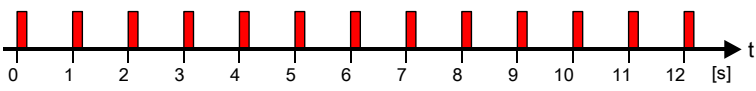
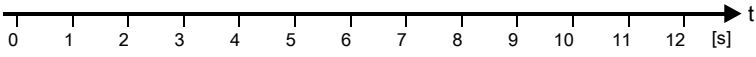
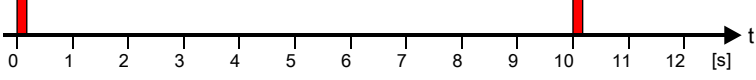
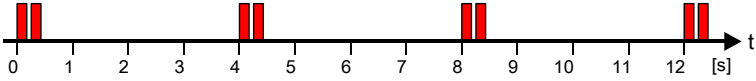

Several flashing patterns are available for normal operation. The flashing pattern is selected using the 'Cerberus-Engineering-Tool' software.

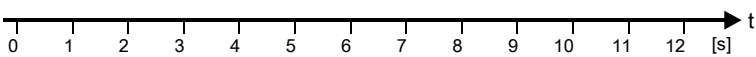
Operating condition		Flashing mode	Graphic
Alarm		IAI flashes red once a second	
Normal	Configuration 1 (default)	IAI off	
	Configuration 2	IAI flashes red every 10 seconds	
Test mode	Normal	IAI flashes red twice every 4 seconds	
	Alarm	IAI flashes red twice every 4 seconds and red every second in-between	
Fault		IAI off	



Not all fire control panels support the flashing patterns described.



A steady-on flashing mode for the alarm and an alternative flashing mode for normal operation can be set using the 'Cerberus-Engineering-Tool' software.





The above graphics are not valid in countries in which the alarm is indicated by an alarm indicator that lights up permanently. For more information, please contact your regional company.

Please also observe the documentation for your fire detection system.

External alarm indicators

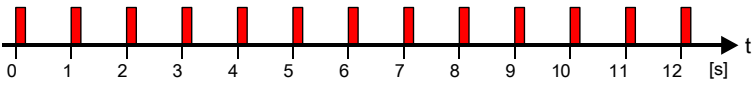
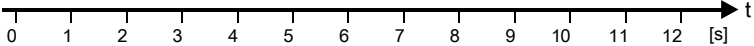
The table below describes the flashing behavior of external alarm indicators in combination with a point detector with an ES ≥ 10 :

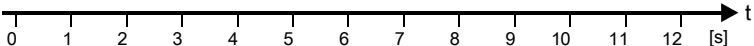
Operating condition		Flashing mode	Graphic
Alarm		EAI flashes red every second	
Normal	Configuration 1 (default)	EAI off	
	Configuration 2	EAI flashes red every 10 seconds	
Fault		EAI off	



Information about the product version of your point detector can be found in the 'Product version ES [→ 16]' chapter.

See also

 Applicable documents [→ 7]

3.3.7 Connection for external alarm indicators

Two external alarm indicators can be connected to each detector. On the C-NET, it is possible to connect the external alarm indicator to any detector. The trigger for activating the alarm indicator can be programmed at the control panel.



The flashing behavior of the point detectors in the case of ES ≥ 10 is described in the 'Extended flashing behavior of alarm indicators in the case of ES ≥ 10 [→ 22]' chapter.



Information about the product version of your device can be found in the 'Product version ES [→ 16]' chapter.

3.3.8 Test mode

It is possible to set all the detectors to test mode for testing purposes. Optical detectors can be tested with the detector tester RE8ST and the test gas REF8 or REF8-S. Heat detectors can be tested with a hot air fan.

3.3.9 Behavior in degraded mode

Applicable for the C-NET:

When the main processor of the fire control panel fails, the control panel works in degraded mode operation. Depending on the control panel type, the fire control panel can continue to perform the most important alarming and signaling functions in degraded mode operation.

Behavior of control panels that support degraded mode operation:

- Alarming is still ensured in degraded mode operation. However, in degraded mode only collective alarming is possible. This means that in the event of an alarm, it is possible to identify the C-NET detector line but not the exact location of the detector triggering the alarm.

When a sounder base DBS720 is connected to the output for the external alarm indicator, it is activated in degraded mode in the case of a fire alarm.

Degraded mode operation on the C-NET is not supported in the same way by all control panels. The information in the 'List of compatibility' and in the corresponding control panel documentation must be taken into account during project planning.

3.3.10 Line tester

The line tester FDUL221 is able to recognize and localize the following errors on the C-NET:

- Wiring error
- Open line
- Short-circuit
- Ground fault

In addition, the line tester recognizes the devices connected to the C-NET detector line.

You will find more information in document 008250.

See also

 [Applicable documents \[→ 7\]](#)

3.4 Mechanical setup

One of the following devices is required to install a point detector:

- Detector base DB72x
- Sounder base DBS720

After installing the detector base or sounder base, simply insert the point detector in the base and turn it, either manually or using the detector exchanger DX791, until you hear and feel it snap in.

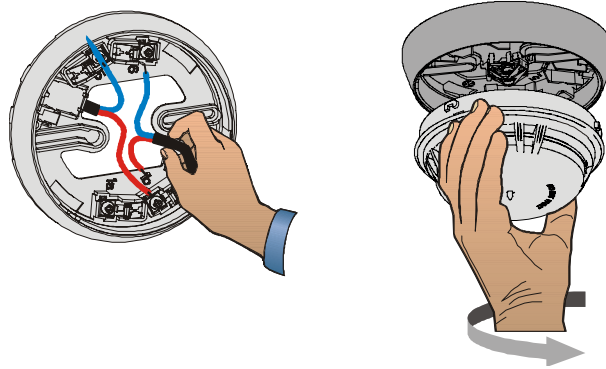

Properties

- Quick installation and secure contact
- The centered alarm indicator makes an alignment of the detector base superfluous
- Space for up to 4 auxiliary terminals

Accessories are available for a variety of different applications and can be combined to suit the particular application in question.

See also

📄 Accessories [→ 26]

3.5 Accessories

3.5.1 Detector base with loop contact DB721

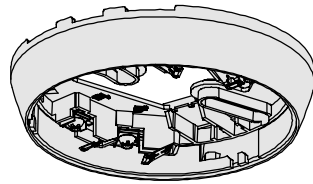

- For the mounting of point detectors
- Thanks to the loop contacts, the detector line is not interrupted when there is no point detector installed in the detector base.
- For the recess-mounted cable entry
- For surface-mounted cable entry, up to 8 mm cable diameter
- Cable connection via screw terminals
- Compatible with:
 - Multi-sensor fire detector OH720
 - Smoke detector OP720
 - Heat detector HI720
 - Heat detector HI722
 - Multi-sensor smoke detector, ASA OOH740
 - Neural fire detector OOH740
 - Interbase DBS72x
 - Air sampling smoke detection kit FDBZ290
- Order number: S54319-F11-A1

See also

 Detector base DB72x [→ 37]

3.5.2 Detector base DB722

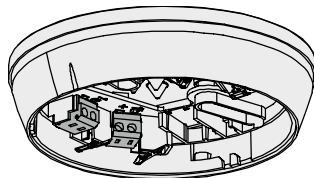

- For the mounting of point detectors
- Thanks to the loop contacts, the detector line is not interrupted when there is no point detector installed in the detector base.
- For the recess-mounted cable entry
- For surface-mounted cable entry, up to 8 mm cable diameter
- Seal integrated in the detector base. Protection category: IP42.
- Cable connection via socket strip
- Compatible with:
 - Multi-sensor fire detector OH720
 - Smoke detector OP720
 - Heat detector HI720
 - Heat detector HI722
 - Multi-sensor smoke detector, ASA OOH740
 - Neural fire detector OOH740
- Order number: S54319-F19-A1

See also

 Detector base DB72x [→ 37]

3.5.3 Detector base DB720

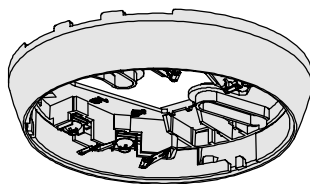

- For the mounting of point detectors
- For the recess-mounted cable entry
- For surface-mounted cable entry, up to 8 mm cable diameter
- Compatible with:
 - Multi-sensor fire detector OH720
 - Smoke detector OP720
 - Heat detector HI720
 - Heat detector HI722
 - Multi-sensor smoke detector, ASA OOH740
 - Neural fire detector OOH740
 - Interbase DBS72x
- Device can no longer be ordered

See also

 Detector base DB72x [→ 37]

3.5.4 Sounder base DBS720

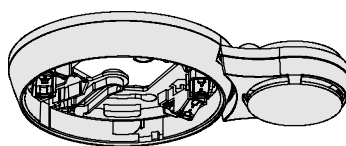

- For acoustic alarming in the case of an event
- Thanks to the loop contacts, the detector line is not interrupted when there is no point detector installed in the sounder base.
- For the C-NET detector line
- For the recess-mounted cable entry
- For surface-mounted cable entry, up to 8 mm cable diameter
- Compatible with:
 - Multi-sensor fire detector OH720
 - Smoke detector OP720
 - Heat detector HI720
 - Heat detector HI722
 - Multi-sensor smoke detector, ASA OOH740
 - Neural fire detector OOH740
- You will find more information in document A6V10218037
- Order number: S54319-F5-A1

See also

 Sounder base DBS720 [→ 39]

3.5.5 Designation plate FDBZ291

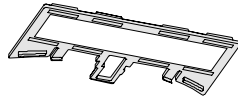

- To identify the location
- Compatible with:
 - Detector base DB72x
 - Sounder base DBS720
- Order number: A5Q00002621

See also

 Designation plate FDBZ291 [→ 46]

3.5.6 Detector base seal RS720

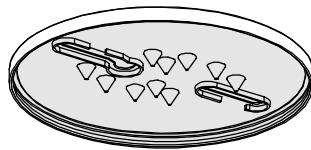

- For mounting in wet rooms
- Protection category IP42
- Compatible with:
 - Detector base DB72x
 - Sounder base DBS720
- Order number: S54319-F8-A1

See also

 Detector base seal RS720 [→ 40]

3.5.7 Base attachment BA720

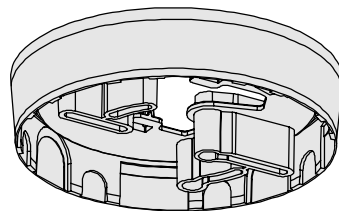

- There are several potential break-out points in the base attachment for surface-mounted cable entry
- For the recess-mounted cable entry
- Permanent connection and joint mounting with detector base
- Compatible with:
 - Detector bases DB72x
- Order number: S54319-F20-A1

See also

 Base attachment BA720 [→ 41]

3.5.8 Base attachment wet BA721

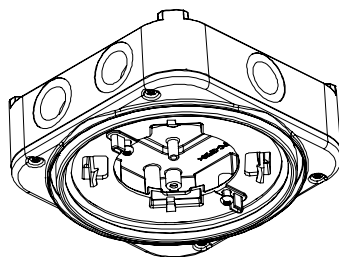

- For mounting in humid, wet environments and if the detector heating unit is used
- Protection category achievable: IP44
- Six break-out points for M20 x 1.5 metal cable glands
- Compatible with:
 - Detector base DB72x/DB110xx/DB721D
 - Detector heating unit FDBH291
 - Designation plate DBZ1193A
 - M20 x 1.5 metal cable gland
- Order number: S54319-F29-A1

See also

📄 Base attachment wet BA721 [→ 42]

3.5.9 Designation plate DBZ1193A

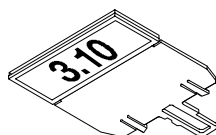

- To identify the location
- Compatible with:
 - Base attachment wet FDB295/BA721
 - Base attachment, surface-mounted, humid DBZ1192
 - DBW1171 base
 - Interbase DBS72x
- Order number: BPZ:4864330001

3.5.10 Detector heating unit FDBH291

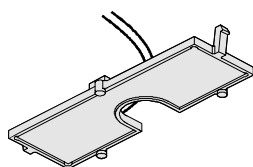

- For operating point detectors in critical ambient conditions during icy conditions or when there is a danger of moisture condensation
- Compatible with:
 - Addressable detector base FDB2x1/FDB2x1-AA
 - Flat detector base FDB2x2
 - Base attachment wet FDB295/BA721
- Order number: A5Q00004439

See also

📄 Detector heating unit FDBH291 [→ 51]

📄 Base attachment wet BA721 [→ 42]

3.5.11 Protective cage DBZ1194

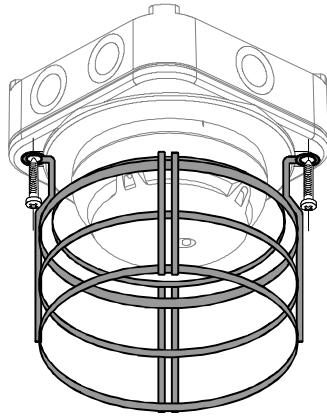

- To protect the devices against mechanical damage
- Can only be used in conjunction with the following accessories:
 - Base attachment wet FDB295
 - Base attachment wet BA721
- Order number: BPZ:4677110001

See also

 Base attachment wet BA721 [→ 42]

3.5.12 Detector locking device LP720

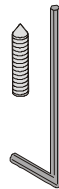

- For protection against theft
- Compatible with:
 - Multi-sensor fire detector OH720
 - Smoke detector OP720
 - Heat detector HI720
 - Heat detector HI722
 - Multi-sensor smoke detector, ASA OOH740
 - Neural fire detector OOH740
 - Interbase DB72x
 - Base (wall mounting) FDB226-x
 - Base deep (wall mounting) FDB227-x
- Order number: S54319-F9-A1

See also

 Detector locking device LP720 [→ 45]

3.5.13 Micro terminal DBZ1190-AA

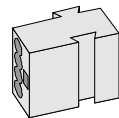

- Auxiliary terminal for connecting cables
- For T-branches of additional cabling e.g. for detector heating units, sounder base, external alarm indicators etc.
- For conductor cross-sections of 0.28...0.5 mm²
- 4-pin
- Order number: BPZ:4677080001

See also

 Auxiliary terminals DBZ1190-AA/-AB [→ 48]

3.5.14 Connection terminal DBZ1190-AB

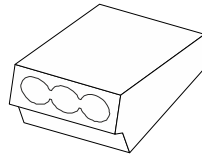

- Auxiliary terminal for connecting cables
- For T-branches of additional cabling, e.g., for cable shielding, detector heating units, sounder base, external alarm indicators, etc.
- For conductor cross-sections of 1...2.5 mm²
- 3 poles
- Order number: BPZ:4942340001

See also

📄 Auxiliary terminals DBZ1190-AA/-AB [→ 48]

4 Planning

4.1 Compatibility

Compatible with control panels that support the C-NET detector line.

Detector line	Control panel				
	FC20xx	FC72x	FC361-xx	SIGMASYS	AlgoRex
FDnet	X		-	-	-
C-NET	-	X	X	-	-

X = compatible

- = not compatible

You will find detailed information in the 'List of compatibility'.

See also

 Applicable documents [→ 7]

4.2 Multi-sensor smoke detector

Like all optical smoke detectors, the multi-sensor smoke detector OH720 is able to detect slow-burning fires that generate smoke.

However, when compared to standard optical smoke detectors, the multi-sensor smoke detector OH720 also offers improved response behavior in the event of open fires and increased resistance to misleading sources of false alarms.

Multi-sensor smoke detector OH720 has two parameter sets available for selection.

4.2.1 Parameter sets

(Parameter set numbers and comments in brackets)

Robust (1/Default):

The parameter set 'Robust' offers improved resistance to false alarms in areas where misleading sources, such as cigarette smoke or exhaust fumes, may cause these to be triggered.

Sensitive (2):

This parameter set is particularly suitable for areas where few misleading sources of false alarms are present, and where priority is given to detecting open fires as early as possible.

The procedure for setting the parameter set via the control panel is described in the control panel documentation.

4.2.2 Specifications

The following table shows the properties of the parameter sets for the multi-sensor smoke detector OH720:

No.	Name	Thermal				
		Typ. Response time	Sensitivity	Static activation temperature	Differential activation temperature ¹	Differential activation possible from:
		[s]	[%/m]	[°C]	ΔT [K]	[°C]
1	Robust	35	3.5	60	25 ²	10
2	Sensitive	10	2.5	60	25 ²	10

¹ Applicable with fast temperature increases >10 K/min.

² Between 1 K/min and 10 K/min, this value increases by a few degrees.



All parameter sets meet the criteria of standard EN 54-7.

4.3 Smoke detector

The optical smoke detector OP720 demonstrates quick response behavior in the event of slow-burning fires that generate smoke. It is extremely well suited to general-purpose applications.

The optical smoke detector OP720 has two parameter sets available for selection.

4.3.1 Parameter sets

(Parameter set numbers and comments in brackets)

Standard (1/Default):

For standard applications, such as in corridors, bedrooms, offices, and living rooms.

Sensitive (2):

For areas with few misleading sources of false alarms, such as cigarette smoke, exhaust fumes, and steam.

The procedure for setting the parameter set via the control panel is described in the control panel documentation.

4.3.2 Specifications

The following table shows the properties of the parameter sets for the smoke detector OP720:

No.	Name	Response time [s]	Sensitivity [%/m]
1	Standard	10	2.5
2	Sensitive	10	1.8



All parameter sets meet the criteria of standard EN 54-7.

4.4 Heat detector

The heat detectors HI720 and HI722 respond when the temperature exceeds a preset threshold value.

Heat detectors are used in environments where misleading sources of false alarms are present and where, if smoke detectors were to be used, an unacceptable number of false alarms would be triggered.

If parameterized appropriately, the heat detector HI720 can recognize sharp increases in temperature and is suitable for areas with a stable ambient temperature.

4.4.1 Parameter sets

The heat detectors HI720 and HI722 have the following parameter sets (parameter set number and comments in brackets):

- A2S (1/Default)
- A2R (2, HI720 only)

Explanation of designation 'A'

- 'A' parameter sets should be applied at an ambient temperature of approximately 25°C. However, they can be applied at temperatures up to 50°C. The static response temperature is 60°C.

Explanation of designations 'R' and 'S'

- In comparison to the S-parameter sets, R-parameter sets also trigger alarms in the event of a temperature increase (e.g., from 20°C to 50°C within a few minutes).

Explanation of designation '2'

A number '2' appearing between letters denotes the room height according to the EN 54-5 standard:

- 2 = room height max. 6 m

The procedure for setting the parameter set via the control panel is described in the control panel documentation.

4.4.2 Specifications

The following table shows the properties of the parameter sets for the heat detectors HI720 and HI722:

No.	Name	Operating temperature typ. / max.	Static activation temperature ¹	Differential activation temperature ²	Differential activation possible from:
		[°C]	[°C]	ΔT [K]	[°C]
1	A2S 60 °C maximum	25 / 50	60	–	–
2	A2R 60 °C rate of rise	25 / 50	60	25 ³	10

¹ Applicable with slow temperature increases <1 K/min.

² Applicable with fast temperature increases > 10 K/min.

³ Between 1 K/min and 10 K/min, this value increases by a few degrees.



All parameter sets meet the criteria of standard EN 54-5.

5 Mounting / Installation

5.1 Required space

- Upon insertion of the detector base and sounder base, the detector base is placed under stress by compression, tension, and torsion. The fastening method must, therefore, be designed accordingly.
- Detector bases and sounder bases must be placed flat on the ceiling.
- Avoid mounting on steps, concrete ribs, etc.
- Install the detector base or sounder base directly on the recessed box or a level surface.
- If a surface-mounted cable feed is used, there are two possible break-out points on the detector base or sounder base for the cable entry. Max. cable diameter: 8 mm.
- The point detector must have at least 2 cm of free space to the side. Only then can the point detector be removed with the detector exchanger DX791.
- Contorted detector bases or sounder bases will complicate or even impede the insertion of detectors.

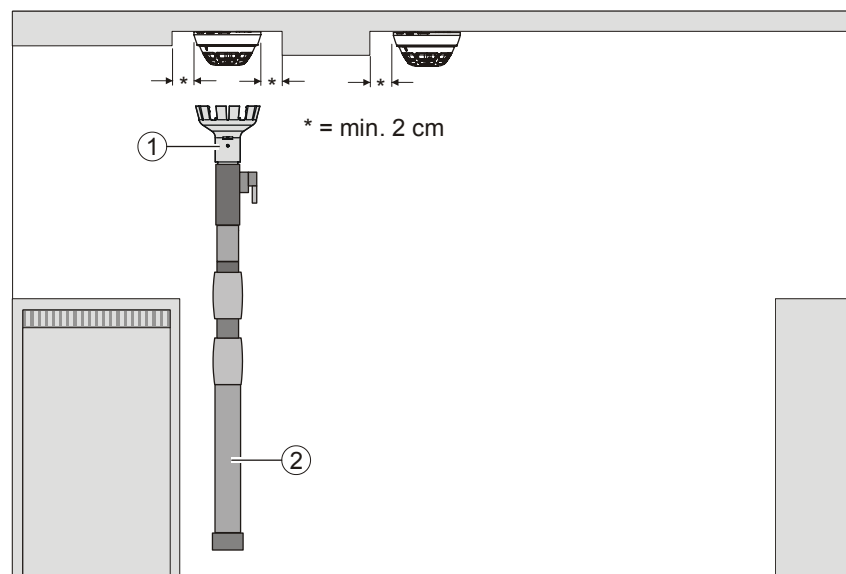

1 Detector exchanger

2 Telescope or extension rod

5.2 Detector base DB72x

- Install the detector base DB72x directly on the ceiling.
- Insert the cables into the detector base. You have the option of using the following types of line:
 - Recess-mounted cable entry
 - Surface-mounted cable entry (cable diameter max. 8 mm)

!	NOTICE
	<p>Incorrect laying of cables</p> <p>Damage to cables and difficulties when installing the point detector</p> <ul style="list-style-type: none"> • The cable loops must be placed flat in the base bottom. • The bare length of the cables is approximately 8...10 mm.

!	NOTICE
	<p>Excessively large holes in detector base seal DB722</p> <p>Potential IP protection category impaired</p> <ul style="list-style-type: none"> • Do not cut or drill holes in the detector base seal. • Without using a tool, push the lines through the detector base seal.

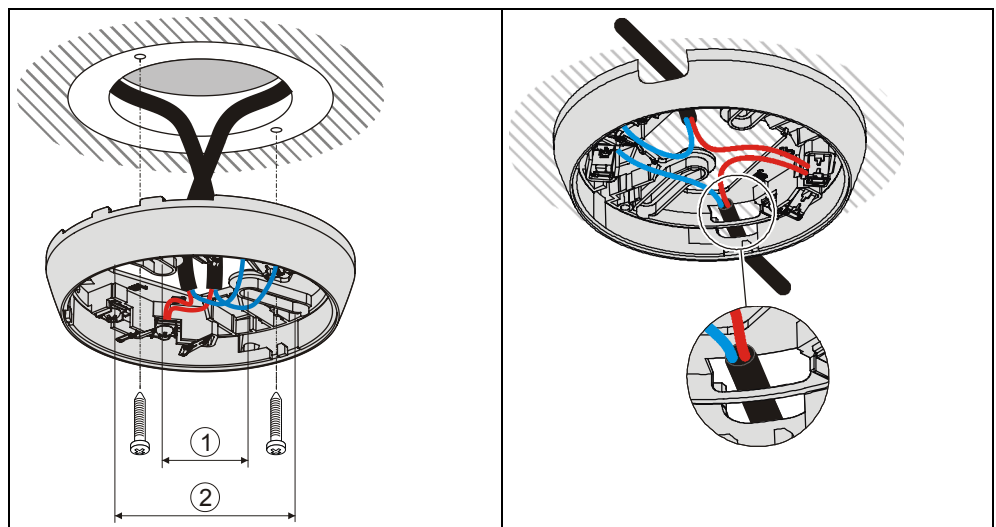

1 Minimum Ø 40 mm

2 Maximum Ø 90 mm



In the case of the detector base DB721, the C-NET detector line is not interrupted even if a point detector is not used.

Detector line connections

The following detector bases have screw terminals:

- DB721
- DB720

The following detector bases have sockets:

- DB722

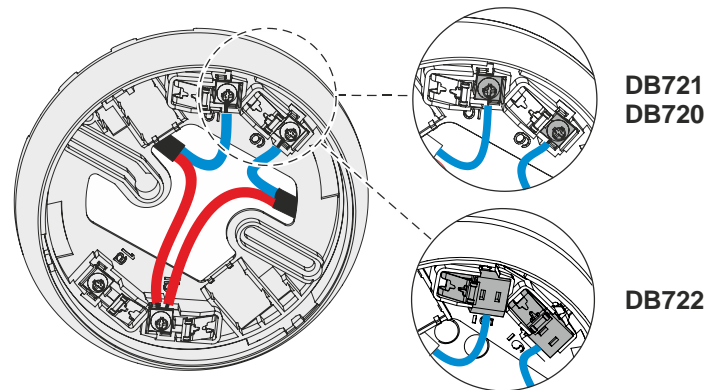

Figure 3: Screw terminals and sockets

See also

- 📄 Cable entry [→ 47]

5.3 Sounder base DBS720

1. Install the sounder base DBS720 directly on the ceiling.
2. Insert the cables into the sounder base DBS720. You have the option of using the following types of line:
 - Recess-mounted cable entry
 - Surface-mounted cable entry (cable diameter max. 8 mm)

!	<p>NOTICE</p> <p>Incorrect laying of cables</p> <p>Damage to cables and difficulties when installing the point detector</p> <ul style="list-style-type: none"> • The cable loops must be placed flat in the base bottom. • The bare length of the cables is approximately 8...10 mm.
----------	--

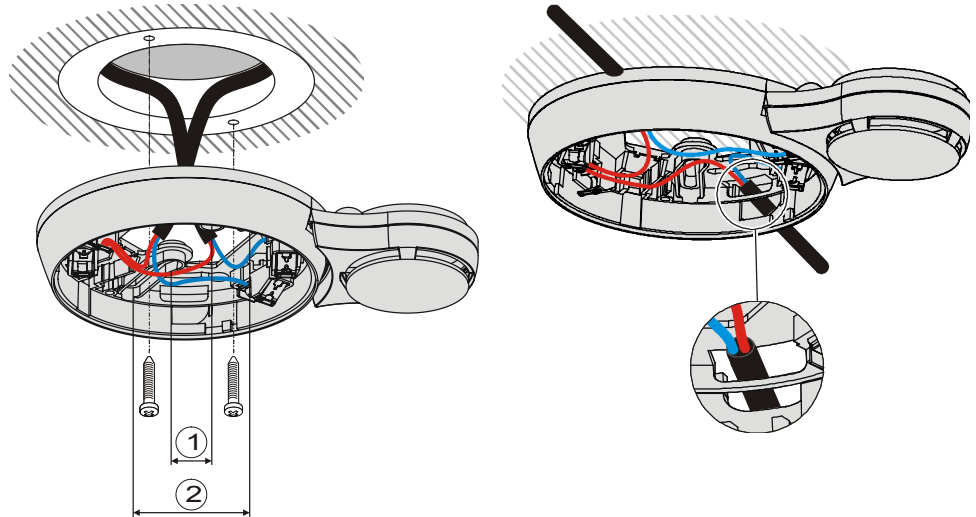

1 Minimum Ø 40 mm

2 Maximum Ø 90 mm



In the case of the sounder base DBS720, the C-NET detector line is not interrupted even if a point detector is not used.

5.4 Detector base seal RS720

- Use the detector base seal RS720 to install point detectors in wet rooms. Protection category: IP42.
- Compatible with the detector bases DB72x and the sounder base DBS720.
- Only use for recess-mounted cable entry.

Installing the detector base seal

1. **NOTICE! Excessively large holes in the detector base seal will impair the potential IP protection category.** Do not cut or drill holes in the detector base seal. Without using a tool, push the lines through the detector base seal.
2. Fit the detector base seal RS720 between the ceiling and the detector base DB72x or the sounder base DBS720.

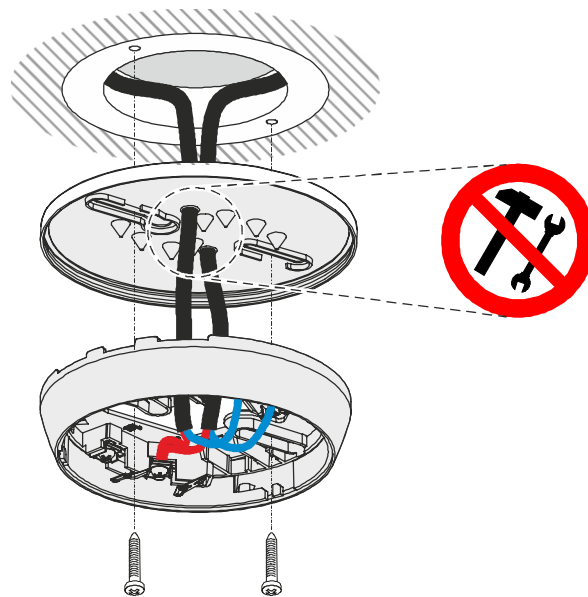

Figure 4: Installing the detector base seal RS720

See also

- 📄 Detector base seal RS720 [→ 28]

5.5 Base attachment BA720

Install base attachment BA720 if you are using a cable with a diameter >8 mm for surface-mounted cable entry.

The base attachment BA720 is attached to the ceiling together with a detector base.

Compatible with the detector bases DB72x and DB110x.

Mounting for recess-mounted cable entry:

1. Insert the cables into the base attachment BA720 (1).
2. Install the base attachment BA720 (1) on the ceiling together with a detector base (2).
3. Connect the cables in the detector base (2).

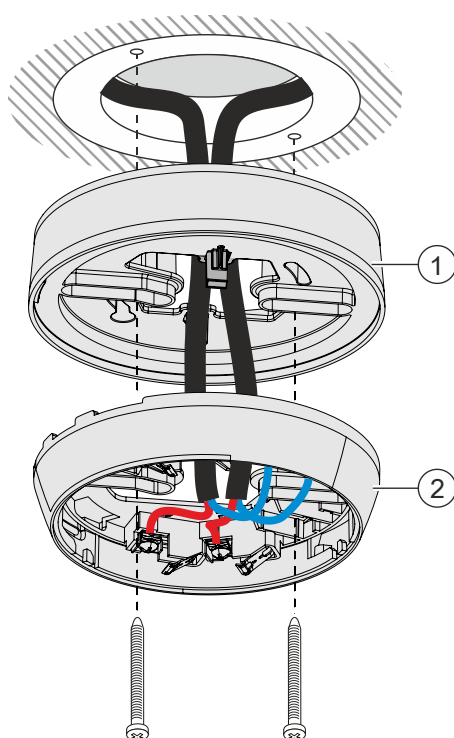

Figure 5: Recess-mounted cable entry with base attachment BA720

1 Base attachment BA720

2 Detector base DB72x

Mounting for surface-mounted cable entry:

1. Break out the areas required for cable entry in base attachment BA720 (1).
2. Insert the cables into the base attachment BA720 (1) through the broken-out areas.
3. Install the base attachment BA720 (1) on the ceiling together with a detector base (2).
4. Connect the cables in the detector base (2).

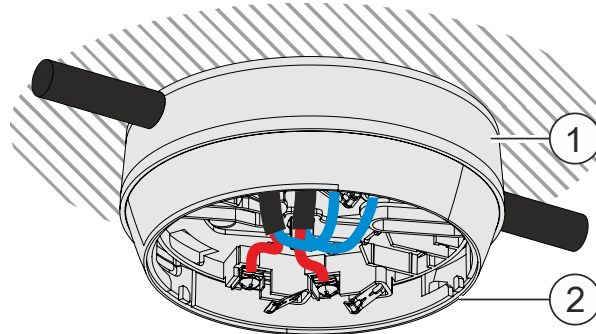

Figure 6: Surface-mounted cable entry with base attachment BA720

1 Base attachment BA720

2 Detector base DB72x

5.6 Base attachment wet BA721

Base attachment wet BA721 is for surface-mounted feed lines in humid and cold environments. The cables are inserted using M20 x 1.5 metal cable glands (Fig. 3). Protective cages DBZ1194/FDBZ294 can be installed on 'base attachment wet BA721'.

- Protective cage DBZ1194 (Fig. 3) protects the detector against mechanical damage.
- EMC-protective cage FDBZ294 (Fig. 4) protects the detector against mechanical damage and electromagnetic fields.



Note the dimensions of the protective cages (Fig. 3) before installing base attachment wet BA721!

You will find information on connecting detector heating unit FDBH291 in the 'Connection of the detector heating unit [→ 52]' chapter.

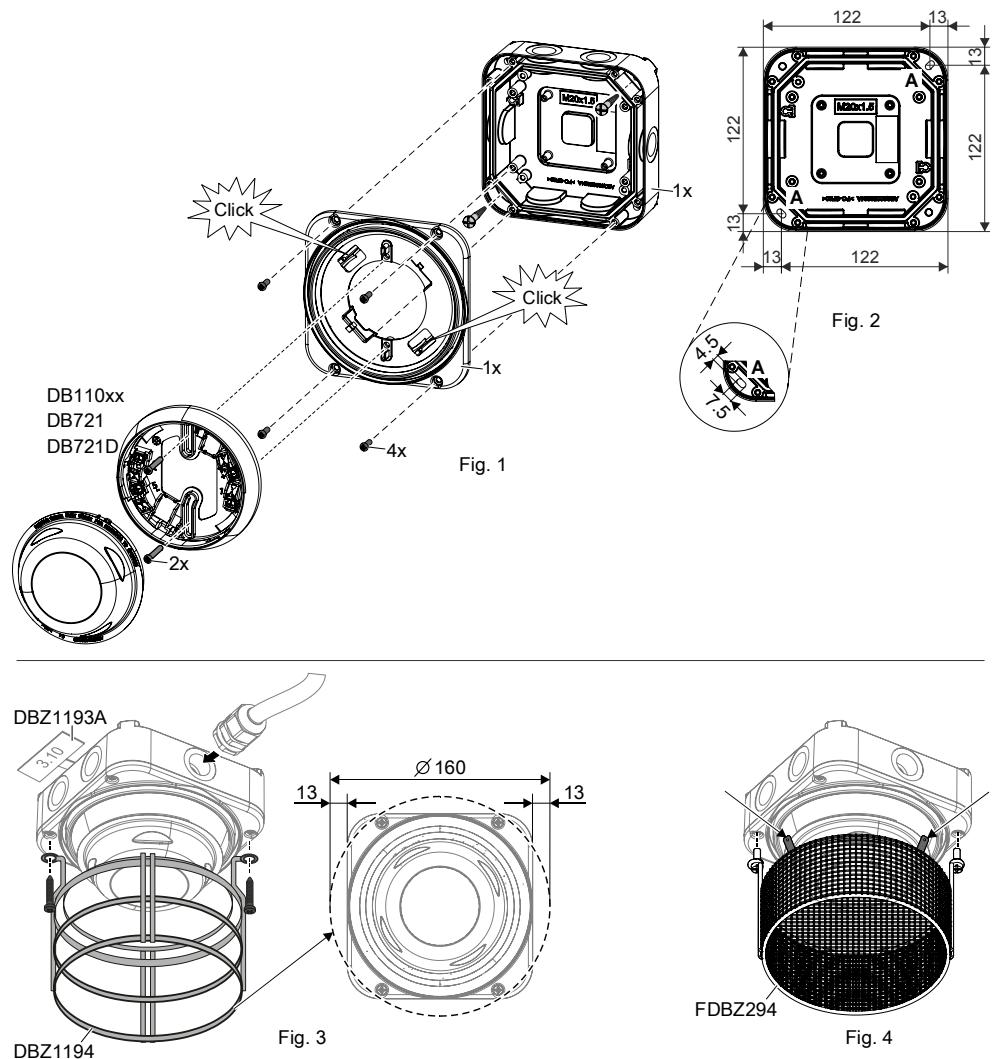

Figure 7: Installation and removal of protective cages and designation plates on base attachment wet BA721

- Fig. 1 Installation of base attachment wet BA721
- Installation on back box on substructure (2 screws)
 - Installation of housing cover on back box (4 screws)
 - Installation of detector base (2 screws)
- Fig. 2 Master gauge for recesses
- Fig. 3 Installation of protective cage DBZ1194, M20 x 1.5 metal cable gland, designation plate DBZ1193A
- Fig. 4 Installation of EMC-protective cage FDBZ294



⚠ WARNING

Danger of falling

Danger of injury

- When installing, use a secured ladder or work platform.
- Only use detector exchanger DX791 as an installation tool.

Installation (Fig. 1 and Fig. 2)

1. Install the M20 x 1.5 metal cable gland(s) in the back box of the base attachment wet.
2. Fit the back box securely to the substructure with 2 screws (detail A).
3. Screw the housing cover to the back box with the 4 screws.
4. Push the detector base into base attachment wet BA721.
⇒ You must be able to hear the detector base click into place.
5. Screw the detector base securely onto base attachment wet BA721 using 2 screws.

Removing the detector base

1. Loosen the two screws on the detector base.
2. Disengage the lock with a screwdriver ('click').
3. Remove the detector base from base attachment wet BA721.

See also

- 📄 [Detector heating unit FDBH291 \[→ 51\]](#)
- 📄 [Base attachment wet BA721 \[→ 29\]](#)
- 📄 [Protective cage DBZ1194 \[→ 30\]](#)
- 📄 [Detector heating unit FDBH291 \[→ 29\]](#)

5.7 Detector locking device LP720

A point detector can be protected against theft with the detector locking device LP720.

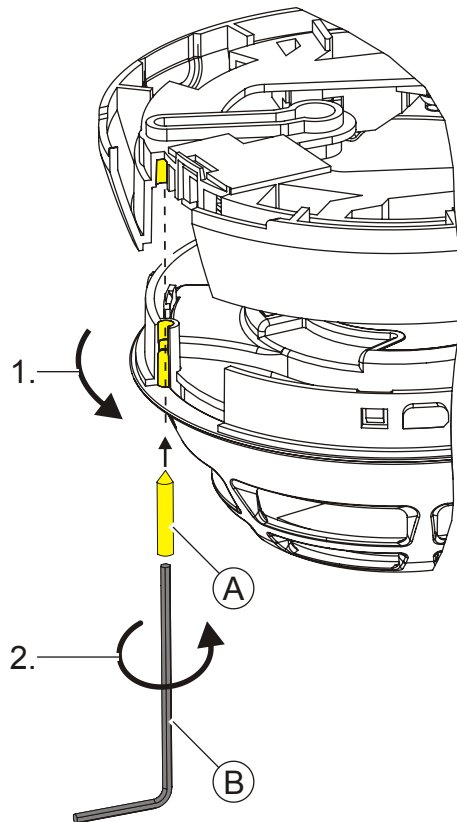

Figure 8: Installing the detector locking device LP720

A Set screw M3 x 12 mm

B Allen key

1. Insert the point detector into the detector base.
2. Using the Allen key provided, insert the set screw through the hole in the detector housing and tighten.

5.8 Designation plate FDBZ291

1. Label designation plate FDBZ291 with location address of point detector.
2. Attach designation plate FDBZ291 to detector base DB72x or sounder base DBS720.



If the detector base seal RS720 is being used, it is not possible to install the designation plate FDBZ291.

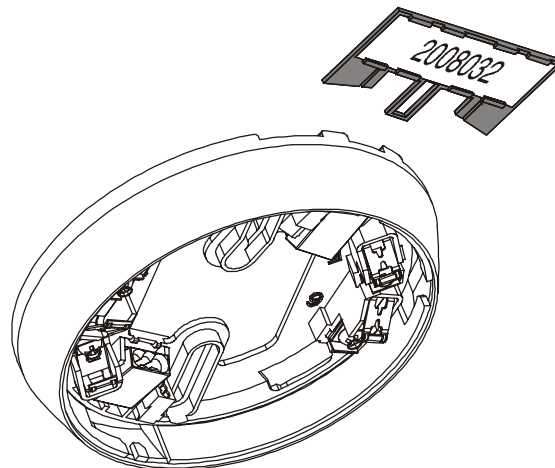

Figure 9: Installation of designation plate FDBZ291

5.9 Cable entry

The detector bases DB72x have four terminals.

- A maximum of 2 cables may be connected to each screw terminal.
- Only one cable may be connected to each socket.

The conductor cross-section is 0.2...1.6 mm².

Designation	Connection
1a	+Connection for external alarm indicator
1b	+C-NET IN and OUT
5	-C-NET IN or OUT / -external alarm indicator
6	-C-NET IN or OUT / -external alarm indicator

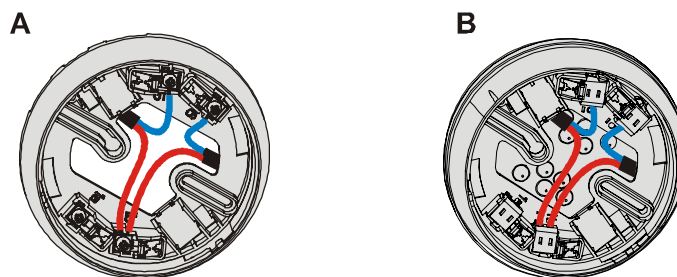

Figure 10: Detector base with screw terminals (A) and sockets (B)

A Screw terminals in the detector base DB721/DB720

B Sockets in the detector base DB722

!	NOTICE
	<p>Incorrect laying of cables Damage to cables and difficulties when installing the point detector</p> <ul style="list-style-type: none"> • The cable loops must be placed flat in the base bottom. • The bare length of the cables is approximately 8...10 mm.

5.9.1 Auxiliary terminals DBZ1190-AA/-AB

Use the following auxiliary terminals for multiple connections:

- DBZ1190-AB connection terminal 1...2.5 mm²
- DBZ1190-AA micro terminal 0.28...0.5 mm²

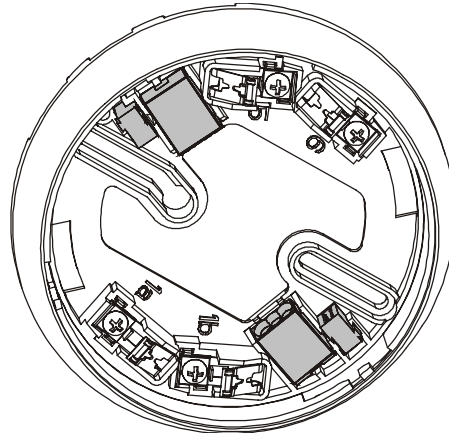

Figure 11: Detector base with connection terminals and micro terminals

See also

- 📄 Connection terminal DBZ1190-AB [→ 31]
- 📄 Micro terminal DBZ1190-AA [→ 30]

5.10 Detector lines

5.10.1 Connection diagram, addressed

Cables and topology

- The connection is established from base to base using twisted or non-twisted wire pairs.
- Wherever possible use twisted, unshielded cables.
- Shielded cables are only required in special cases, such as strong high-frequency fields.
- You have the option of using the following types of line:
 - Loops
 - Stub lines
 - Stub line as a branch of a loop

Connecting external alarm indicators FDAI91 / FDAI92 / FDAI93

Observe the following points when connecting external alarm indicators:

- Wherever possible use twisted, unshielded cables.
- Connect a maximum of two external alarm indicators to one detector.
- If a cable with shielding is used to connect the external alarm indicator, this shielding must be linked to the shielding of the detector bus.
The shielding must not be linked to the external alarm indicator itself.

C-NET connection diagram

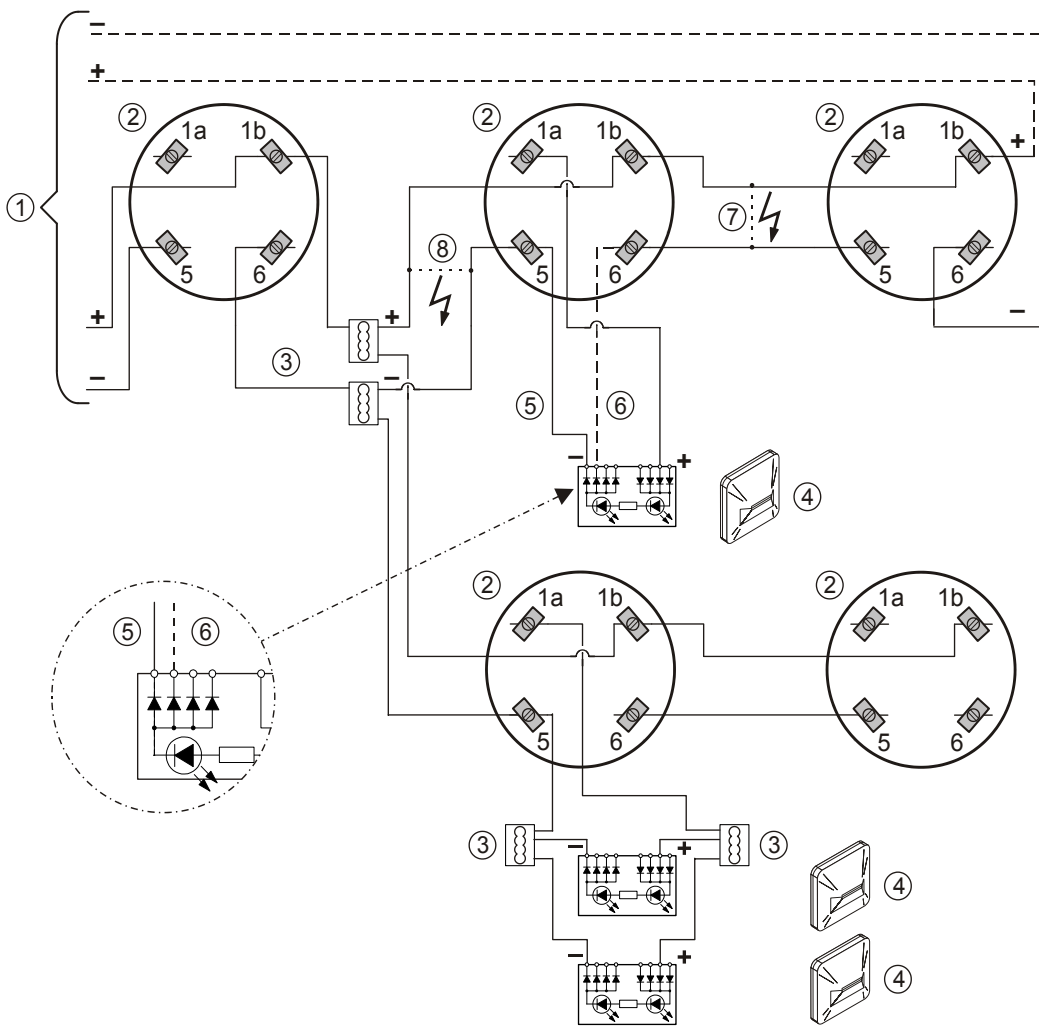

Figure 12: Connection diagram for addressed detector lines

- | | |
|--|--------------------------|
| 1 Control panel | 5 Cable –EAI6 |
| 2 Detector base DB72x, sounder base DBS720 | 6 Cable –EAI5 (optional) |
| 3 Auxiliary terminal DBZ1190-xx | 7 Short circuit (error) |
| 4 External alarm indicator | 8 Short circuit (error) |

The alarm indicator connected will continue to function correctly in the event of a short-circuit occurring at position '7' on the connection diagram. The alarm indicator is triggered by cable –EAI6.

If the short-circuit occurs at position '8' on the connection diagram, the alarm indicator will no longer be triggered.

As an option, the alarm indicator may also be connected using cable -EAI5. In this case, the alarm indicator will correctly indicate an alarm even if a short-circuit occurs at position '8'.

This ensures that the alarm indicator is always functioning correctly.



The option described is possible in loops and stub lines.

You will find more detailed information in the fire detection system documentation.

5.11 Detector dust cap

1. Cover the point detector with the detector dust cap during the construction phase. This will protect the point detector from dust and dirt.
2. Once construction work is complete, remove the detector dust cap from the point detector.

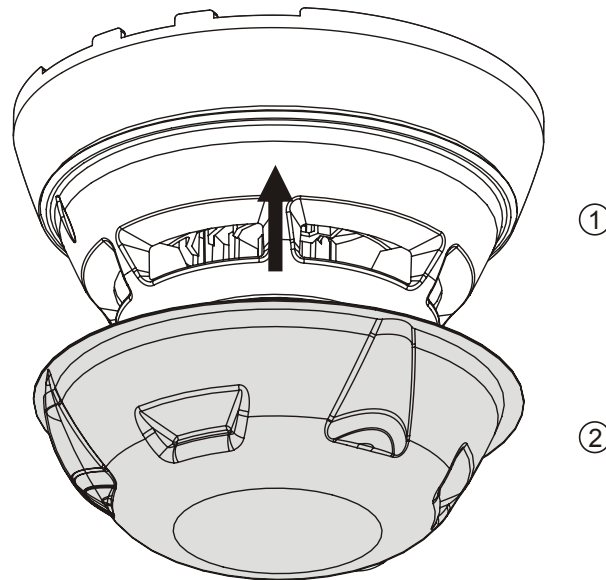

1 Point detector

2 Detector dust cap



A detector dust cap is provided as part of the scope of supply for each point detector.

5.12 Detector heating unit FDBH291

5.12.1 Installation of the detector heating unit

When the detector is exposed to icing or moisture condensation (e.g., in cooling rooms, attics, loading ramps), detector heating unit FDBH291 is installed in the detector base. The detector heating unit increases the detector temperature by approximately 2 °C over the ambient temperature and thus avoids moisture condensation on the detector.



Optimum function of the detector heating unit is only guaranteed with base attachment wet BA721.

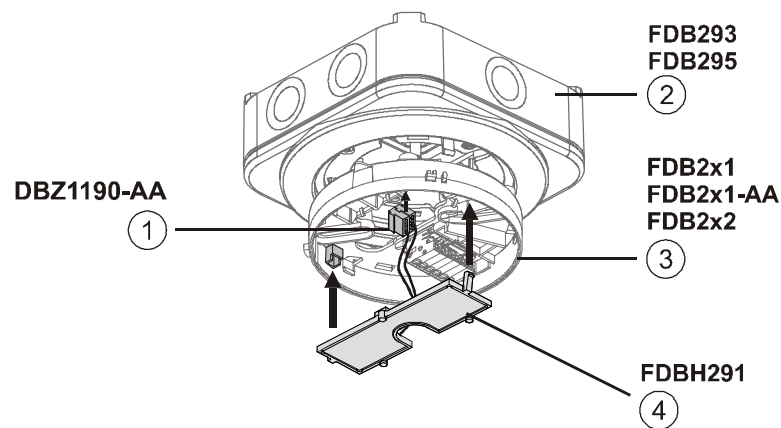

Figure 13: Mounting of the detector heating unit FDBH291

- | | |
|-----------------------|-------------------------|
| 1 Micro terminals | 3 Detector heating unit |
| 2 Base attachment wet | 4 Detector base |

5.12.2 Connection of the detector heating unit

- Connect the cables for the monitored supply from the control panel and the detector heating unit to the supplied micro terminals DBZ1190-AA.
- The cables can be placed in the same cable harness as the detector line or separately.
- Several detector heating units can be connected in parallel.
- Detector heating units require a separate supply.



NOTICE

Risk of icing

Malfunction

- To ensure smooth operation, the detector must be checked regularly for icing.

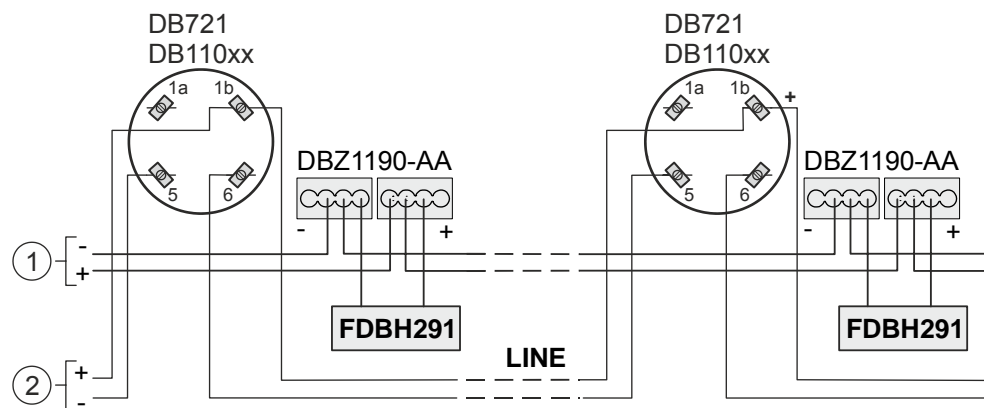

Figure 14: Connection diagram for detector heating unit FDBH291

1 Control panel supply (monitored)

2 Control panel

6 Commissioning

6.1 Commissioning on the C-NET

The devices are commissioned via the control panel. The exact procedure is described in the control panel documentation.

7 Maintenance / Repair

7.1 Performance check

The selftest automatically subjects the detectors to an extensive electrical performance check. Regular performance checks of the detectors are required nonetheless. This may be done with the test gas or hot air fan depending on the detector type.

Recommendation:

- Check the devices every year.
- Replace heavily soiled or damaged devices.
- All detectors should be replaced after 6 to 8 years of service, depending on the ambient conditions.

7.2 Testing detectors



To enable detector testing with test gas or with a hot air fan, the detector must be switched to test mode.

Depending on the detector, testing may be performed with one or more of the following accessories:

- Detector tester RE8ST
- Test gas
 - REF8-S (recommended)
 - REF8
- Hot air fan
- Detector tester RE7T

The following table shows which detectors may be tested with which test aids.

Detector	Test gas / detector tester RE8ST	Hot air fan / detector tester RE7T
OH720	X	X
OP720	X	–
HI720	–	X
HI722	–	X



The flashing behavior of the alarm indicators in test mode is described in the 'Internal alarm indicator in the case of ES <10 [→ 21]' and 'Extended flashing behavior of alarm indicators in the case of ES ≥10 [→ 22]' chapters.



To trigger a detector using test gas, normally 2...4 gas discharges at intervals of approx. 2 seconds are required. When the detector is working in test mode, activation takes place after approximately 10 seconds.

8 Specifications

Unless otherwise mentioned, the following data applies:

Temperature	= 25 °C
Air pressure	= 1000 hPa (750 Torr)

8.1 Multi-sensor smoke detector technical data

The following section lists the technical data for the multi-sensor smoke detector OH720.

You will find information on approvals, CE marking, and the relevant EU directives for this device (these devices) in the following document(s); see 'Applicable documents' chapter:

- Document A6V10202198

Detector line

Operating voltage (modulated)	DC 12...33 V
Operating current (quiescent)	Typ. 230 µA
Maximum current connection factor	1
Quiescent current connection factor	1
Address connection factor	1
Separator connector factor	1
Protocol	C-NET
Compatibility	See 'List of compatibility'

Line separator

Line voltage:	
• Nominal	DC 32 V (= V_{nom})
• Minimum	DC 12 V (= V_{min})
• Maximum	DC 33 V (= V_{max})
Voltage at which the line separator opens:	
• Minimum	DC 7.5 V (= $V_{SO min}$)
• Maximum	DC 10.5 V (= $V_{SO max}$)
Permanent current when switches are closed	Max. 1.5 A (= $I_{C max}$)
Switching current (e.g., in the event of a short-circuit)	Max. 2 A (= $I_S max$)
Leakage current when switches are open	Max. 1 mA (= $I_L max$)
Serial impedance when switches are closed	Max. 0.4 Ω (= $Z_C max$)

The line separator is closed via an actuation signal from the control panel. Required line voltage: DC 12...33 V (normal range)

External alarm indicators	Number of external alarm indicators that can be connected	Max. 2
	Voltage	DC 9...30 V
	Current	10...16 mA
Device characteristics	Response sensitivity at 0.2 m/s (typ.)	2.5 or 3.5 %/m (depending on the parameter set)
	Permissible wind speed	Max. 5 m/s
	Compensation speed	≤1/45 voltage increase for detection/h
	Flashing interval times AI:	
	<ul style="list-style-type: none"> • Bright 15 ms • Dark 1 s 	
Connections	Detector line and external alarm indicators:	
	<ul style="list-style-type: none"> • Design Screw terminal • Cable cross section 2 x 0.2...1.6 mm² 	
Ambient conditions	Operating temperature	-10...+55 °C
	Storage temperature	-30...+70 °C
	Air humidity	≤95 % rel.
	Protection category (IEC 60529):	
	<ul style="list-style-type: none"> • Base DB721, DB720, DBS720 (all installation types) IP40 • Base DB721, DB720, DBS720 with detector base seal RS720 IP42 • Base DB722 IP42 • Base attachment wet BA721 IP44 	
	Electromagnetic compatibility:	
	<ul style="list-style-type: none"> • 10 kHz...1.8 GHz 50 V/m • 1.8 GHz...2.5 GHz 20 V/m 	
Mechanical data	Color	~RAL 9010 pure white
	Dimensions	See chapter 'Dimensions [→ 61]'
Standards	European standards	<ul style="list-style-type: none"> • EN 54-7 • EN 54-17 • CEA 4021
	International standards	<ul style="list-style-type: none"> • IEC 60092-504 • IEC 60533

See also

 Applicable documents [→ 7]

8.2 Smoke detector technical data

The following section lists the technical data for the smoke detector OP720.

You will find information on approvals, CE marking, and the relevant EU directives for this device (these devices) in the following document(s); see 'Applicable documents' chapter:

- Document A6V10202198

Detector line	Operating voltage (modulated)	DC 12...33 V
	Operating current (quiescent)	Typ. 220 μ A
	Maximum current connection factor	1
	Quiescent current connection factor	1
	Address connection factor	1
	Separator connector factor	1
	Protocol	C-NET
	Compatibility	See 'List of compatibility'
Line separator	Line voltage:	
	• Nominal	DC 32 V (= V_{nom})
	• Minimum	DC 12 V (= V_{min})
	• Maximum	DC 33 V (= V_{max})
	Voltage at which the line separator opens:	
	• Minimum	DC 7.5 V (= $V_{SO min}$)
	• Maximum	DC 10.5 V (= $V_{SO max}$)
	Permanent current when switches are closed	Max. 1.5 A (= $I_{C max}$)
	Switching current (e.g., in the event of a short-circuit)	Max. 2 A (= $I_{S max}$)
	Leakage current when switches are open	Max. 1 mA (= $I_{L max}$)
Serial impedance when switches are closed	Max. 0.4 Ω (= $Z_{C max}$)	
The line separator is closed via an actuation signal from the control panel. Required line voltage: DC 12...33 V (normal range)		
External alarm indicators	Number of external alarm indicators that can be connected	Max. 2
	Voltage	DC 9...30 V
	Current	10...16 mA

Device characteristics	Response sensitivity at 0.2 m/s (typ.)	1.8 or 2.5 %/m (depending on the parameter set)
	Permissible wind speed	Max. 5 m/s
	Compensation speed	≤1/45 voltage increase for detection/h
	Flashing interval times AI:	
	<ul style="list-style-type: none"> • Bright 15 ms • Dark 1 s 	
Connections	Detector line and external alarm indicators:	
	<ul style="list-style-type: none"> • Design Screw terminal • Cable cross section 2 x 0.2...1.6 mm² 	
Ambient conditions	Operating temperature	-10...+55 °C
	Storage temperature	-30...+70 °C
	Air humidity	≤95 % rel.
	Protection category (IEC 60529):	
	<ul style="list-style-type: none"> • Base DB721, DB720, DBS720 (all installation types) IP40 • Base DB721, DB720, DBS720 with detector base seal RS720 IP42 • Base DB722 IP42 • Base attachment wet BA721 IP44 	
	Electromagnetic compatibility:	
	<ul style="list-style-type: none"> • 10 kHz...1.8 GHz 50 V/m • 1.8 GHz...2.5 GHz 20 V/m 	
Mechanical data	Color	~RAL 9010 pure white
	Dimensions	See chapter 'Dimensions [→ 61]'
Standards	European standards	<ul style="list-style-type: none"> • EN 54-7 • EN 54-17
	International standards	<ul style="list-style-type: none"> • IEC 60092-504 • IEC 60533

See also

 Applicable documents [→ 7]

8.3 Heat detector technical data

The following section lists the technical data for the heat detectors HI720 and HI722.

You will find information on approvals, CE marking, and the relevant EU directives for this device (these devices) in the following document(s); see 'Applicable documents' chapter:

- Document A6V10202198

Detector line	Operating voltage (modulated)	DC 12...33 V
	Operating current (quiescent)	Typ. 200 μ A
	Maximum current connection factor	1
	Quiescent current connection factor	1
	Address connection factor	1
	Separator connector factor	1
	Protocol	C-NET
	Compatibility	See 'List of compatibility'

Line separator	Line voltage:	
	• Nominal	DC 32 V (= V_{nom})
	• Minimum	DC 12 V (= V_{min})
	• Maximum	DC 33 V (= V_{max})
	Voltage at which the line separator opens:	
	• Minimum	DC 7.5 V (= $V_{SO min}$)
	• Maximum	DC 10.5 V (= $V_{SO max}$)
	Permanent current when switches are closed	Max. 1.5 A (= $I_{C max}$)
	Switching current (e.g., in the event of a short-circuit)	Max. 2 A (= $I_{S max}$)
	Leakage current when switches are open	Max. 1 mA (= $I_{L max}$)
Serial impedance when switches are closed	Max. 0.4 Ω (= $Z_{C max}$)	

The line separator is closed via an actuation signal from the control panel.
Required line voltage: DC 12...33 V (normal range)

External alarm indicators	Number of external alarm indicators that can be connected	Max. 2
	Voltage	DC 9...30 V
	Current	10...16 mA

Device characteristics	Static response temperature with parameter set:	
	• A2S (typ.):	60 °C
	• A2R (typ.):	60 °C
	Flashing interval times AI:	
	• Bright	15 ms
	• Dark	1 s
Connections	Detector line and external alarm indicators:	
	• Design	Screw terminal
	• Cable cross section	2 x 0.2...1.6 mm ²
Ambient conditions	Operating temperature	-10...+55 °C
	Storage temperature	-30...+70 °C
	Air humidity	≤95 % rel.
	Protection category (IEC 60529):	
	• Base DB721, DB720, DBS720 (all installation types)	IP40
	• Base DB721, DB720, DBS720 with detector base seal RS720	IP42
	• Base DB722	IP42
	• Base attachment wet BA721	IP44
	Electromagnetic compatibility:	
	• 10 kHz...2.5 GHz	50 V/m
Mechanical data	Color	~RAL 9010 pure white
	Dimensions	See chapter 'Dimensions [→ 61]'
Standards	European standards	<ul style="list-style-type: none"> • EN 54-5 • EN 54-17
	International standards	<ul style="list-style-type: none"> • IEC 60092-504 • IEC 60533

See also

 Applicable documents [→ 7]

8.4 Dimensions

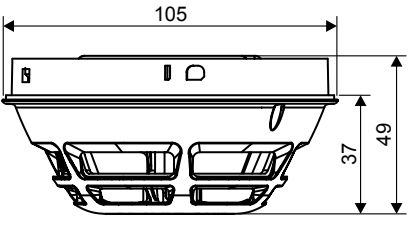
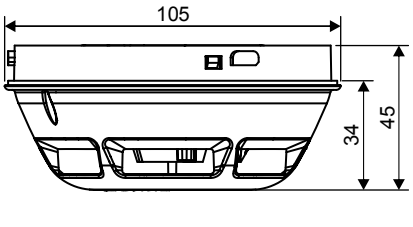
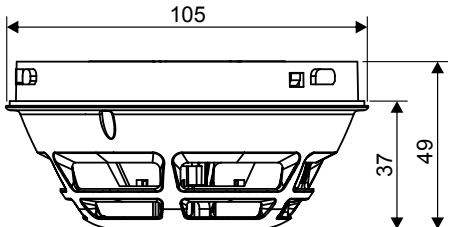
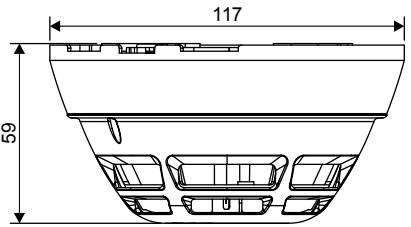
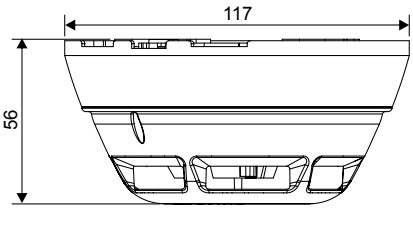
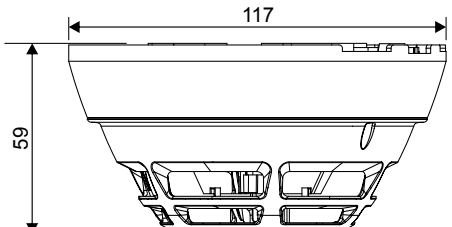
OH720	OP720	HI720, HI722
		
OH720 with base	OP720 with base	HI720, HI722 with base
		

8.5 Environmental compatibility



This equipment is manufactured using materials and procedures which comply with current environmental protection standards as best as possible. More specifically, the following measures have been undertaken:

- Use of reusable materials
- Use of halogen-free plastics
- Electronic parts and synthetic materials can be separated

Larger plastic parts are labeled according to ISO 11469 and ISO 1043. The plastics can be separated and recycled on this basis.



Electronic parts and batteries must not be disposed of with domestic waste.

- Take electronic parts and batteries to local collection points or recycling centers.
- Contact local authorities for more information.
- Observe national requirements for disposing of electronic parts and batteries.

Index

- A**
Alarm indicator
 external 23
Approvals..... 55, 57, 59
Auxiliary terminals
 Connection terminal..... 48
 Micro terminal..... 48
- C**
Cables..... 48
CE marking..... 55, 57, 59
C-NET
 Commissioning detectors..... 53
Collective behavior
 Degraded mode operation 24
Commissioning detectors..... 53
Compatibility..... 32
Compatibility with control panels..... 32
Connection diagram..... 48
 External alarm indicators..... 48
Connection terminal..... 48
Control panel..... 53
- D**
Danger levels..... 20
Degraded mode operation
 Collective behavior 24
 Fire control panel failure..... 24
Designation plate
 Detector base 46
 Installation 46
 Sounder base 46
Detector
 Performance check..... 54
Detector base..... 25
Detector base seal
 Installation 40
Detector dust cap..... 50
Detector exchanger..... 36
Detector heating unit
 Mounting..... 51
Detector line
 Connection diagram..... 48
Detector locking device
 Mounting..... 45
- Diagnosis levels**... Fehler! Textmarke nicht definiert.
 Fault..... Fehler! Textmarke nicht definiert.
 Normal..... Fehler! Textmarke nicht definiert.
 Observe information Fehler! Textmarke nicht definiert.
 Replacement necessary Fehler! Textmarke nicht definiert.
 Replacement recommended .. Fehler! Textmarke nicht definiert.
- Disposal**..... 61
Documentation for fire detection system 7, 22
Download center
 URL..... 7
- E**
Environmental compatibility..... 61
ES
 Product version..... 16
EU directives..... 55, 57, 59
External alarm indicators..... 23
- F**
Fire control panel failure
 Degraded mode operation 24
Flashing behavior
 Steady-on..... 22
Flashing mode
 Internal alarm indicator 22
Flashing pattern
 Configuration 22
 Internal alarm indicator 22
- H**
Heat detector..... 19
 Static..... 15
 Static and differential 15
Hot air fan..... 54
- I**
Internal alarm indicator..... 22
 Alarm..... 22
 Alarm in test mode..... 22
- L**
Line separator
 Function 21
List of compatibility..... 24, 32
Loop..... 48



M		
Maintenance intervals	54	
Micro terminal	48	
Multi-sensor smoke detector	15, 17	
O		
Original language	5	
P		
Packaging label		
Product version.....	16	
Parameter sets.....	20	
Heat detector	35	
Multi-sensor smoke detector	33	
Smoke detector.....	34	
Performance check.....	54	
Product label		
Product version.....	16	
R		
Recycling	61	
Required space.....	36	
S		
Scope	5	
Screw terminals.....	38, 47	
Short-circuit		
Line separator.....	21	
Smoke detector	15, 18	
Socket.....	47	
Sockets	38	
Sounder base	25	
Source language	5	
Standards.....	56, 58, 60	
Steady-on		
Internal alarm indicator	22	
Stub line.....	48	
T		
Terminals		
Assignment.....	47	
Test gas		
REF8.....	54	
REF8-S	54	
Test mode	23	
Testing equipment		
Detector tester RE8ST.....	23	
Hot air fan.....	23, 54	
Test gas	54	
Test gas REF8.....	23	
Test gas REF8-S	23	
Topology	48	
Type plate		
Product version.....	16	
W		
Wide-spectrum smoke detector.....	18	

Issued by
Siemens Switzerland Ltd
Building Technologies Division
International Headquarters
Gubelstrasse 22
CH-6301 Zug
+41 41-724 24 24
www.siemens.com/buildingtechnologies

© Siemens Switzerland Ltd, 2008
Technical specifications and availability subject to change without notice.